

**SPECIFICATIONS****GENERAL**

Sliding windows shall be Marlin series #3500-HC (thermally improved) as manufactured by Marlin windows, and shall conform to ANSI/AAMA 101-88 HS-HC40. Series #3500 shall have a condensation resistance factor of 58.

**MATERIALS**

All frame and sash members shall be aluminum extrusions of 6063-T5 alloy & temper. Frame and sash members shall have a rigid polyurethane "thermal-barrier" as an integral part of the extrusion which eliminates all direct contact between interior and exterior aluminum sections.

**FINISH**

Standard architectural Class II anodic color conforming to Aluminum Association AA-M12-C22-A34 for dark bronze or AA-M12-C22-A31 for clear anodized. (Architectural Class I and Class II anodic finishes and organic coatings available - specify).

**CONSTRUCTION**

Frame members shall be 3 3/8" in depth. Frame and vent corners shall be fabricated to form tight mitered joints. Fixed interlock members shall be fabricated to form tight butt-joints where joined to frame members. All joinery fastened securely with stainless steel self-tapping screws and sealed to prevent moisture and air infiltration. Sill members shall allow drainage of moisture to the exterior, but reduce direct inflow of wind, moisture and dirt. Sill tracks shall be extruded as an integral part of the sill member. Extruded aluminum glass stops shall be fabricated to form tight butt-joints.

**HARDWARE**

Sash shall incorporate adjustable steel ball bearing wheel assemblies at the bottom corners. Rigid vinyl guides shall be located on the top and bottom rails at each corner of the sash to assure smooth operation. A continuous pull handle shall be a part of the interlock stile. A thumb operated latch shall be attached to the interlock stile and shall engage a channel in the fixed interlock when the sash is fully closed. Optional secondary slide bolt available for partial vent opening. Optional stainless steel track recommended for intended heavy use.

**WEATHERSTRIPPING**

Ventilating sash shall have continuous weather-stripping of silicone treated wool pile incorporating a polypropylene fin to insure longer life with better resistance to wind and moisture infiltration. Weather-stripping shall extend around the entire perimeter of the vent.

**GLAZING**

Marlin system #3500 shall be glazed with 1" overall insulating glass. The ventilator shall be 'marine' type glazed with a continuous vinyl channel gasket. The fixed glass shall be set on blocks, back bedded in foam glazing tape and retained by an extruded aluminum stop.

**OPTIONAL SCREEN**

Screen frames shall be fabricated from roll-form aluminum, finish to match window. Screen cloth to be 18 x 16 fiberglass mesh held in the aluminum screen frame with a tight fitting continuous vinyl spline. Two leaf springs shall be attached to the top rail of the screen and two metal pull tabs shall be attached at the bottom rail and held in place by the screen spline.

**INSTALLATION**

Windows shall be installed straight, plumb, and level without twisting and securely anchored in place. Openings shall be properly prepared to provide sufficient space at jambs, head and sill to compensate for normal construction movement without affecting intended use.

**PROTECTION AND CLEANING**

The General Contractor shall provide adequate protection of the aluminum and glass surfaces from damage by grinding compound, lime, acids, cement or other contaminants. The General Contractor shall be responsible for final cleaning.



1/4 SCALE

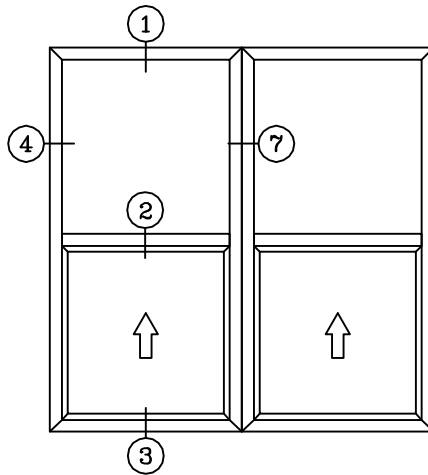
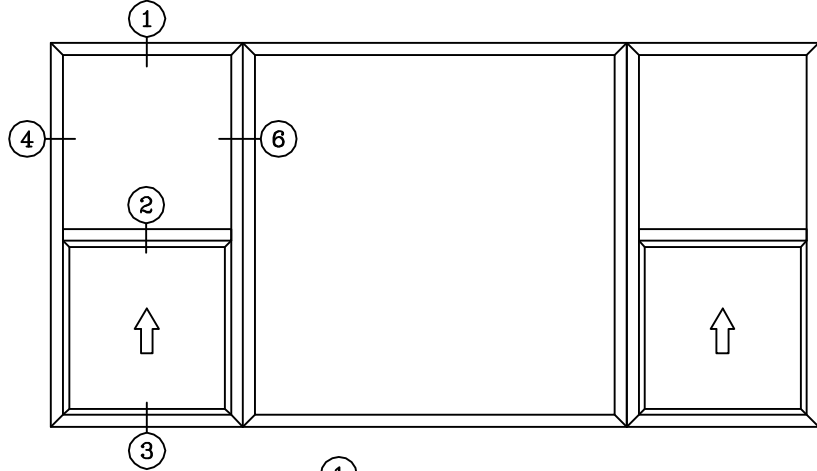
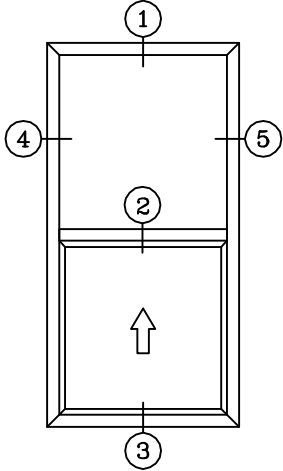

1

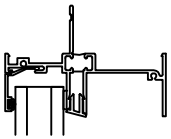

2

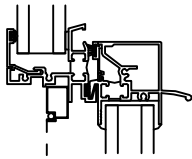

4

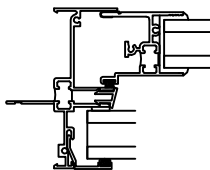

5

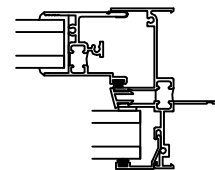

3

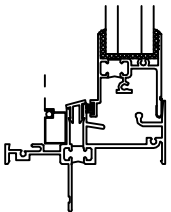

6

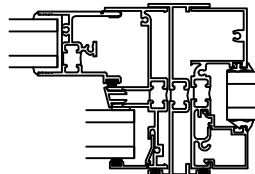

7

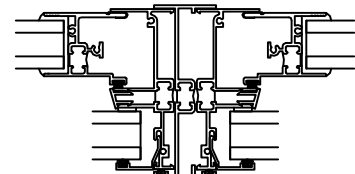

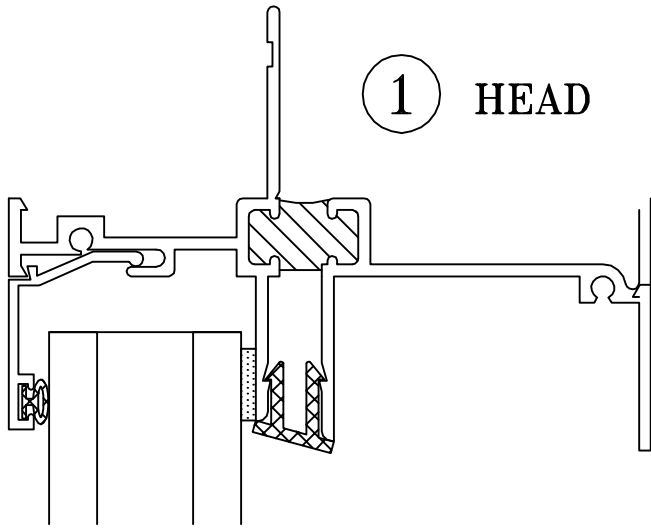

① HEAD

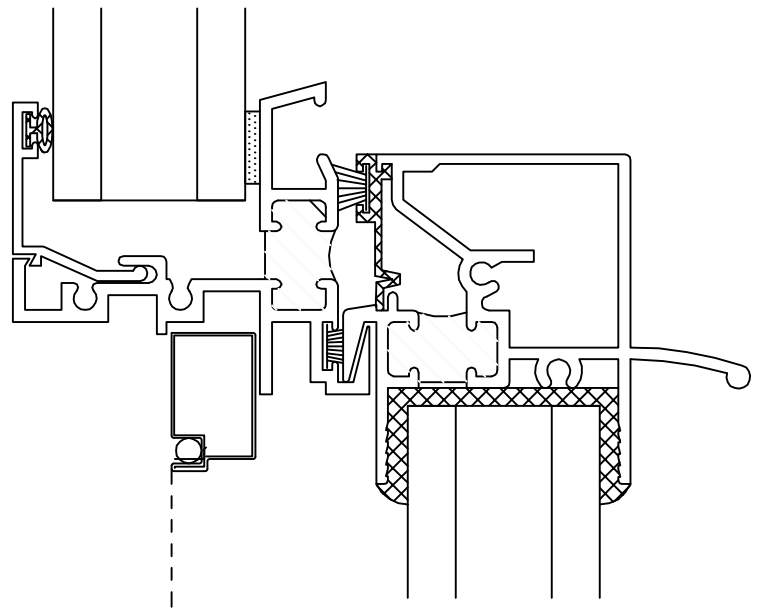

② INTERLOCK

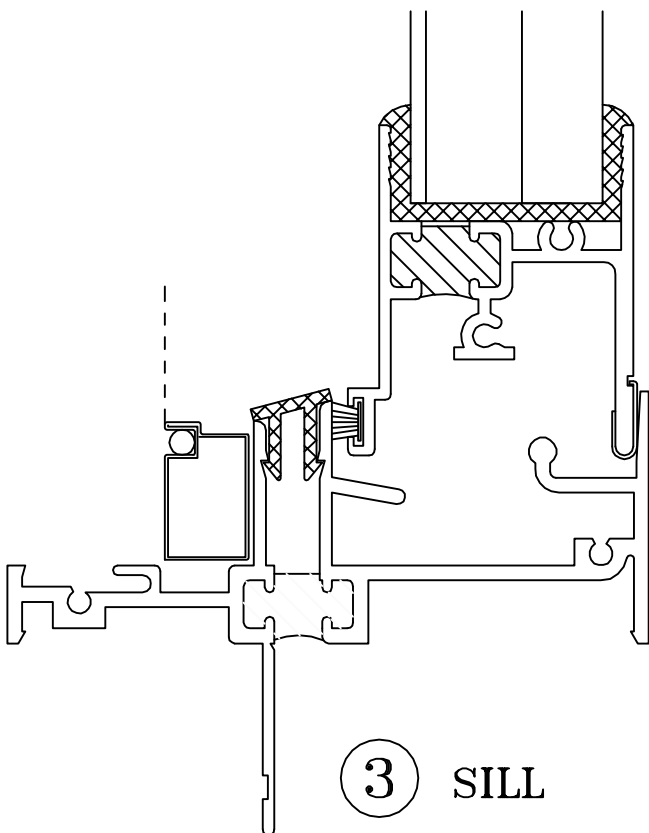

③ SILL

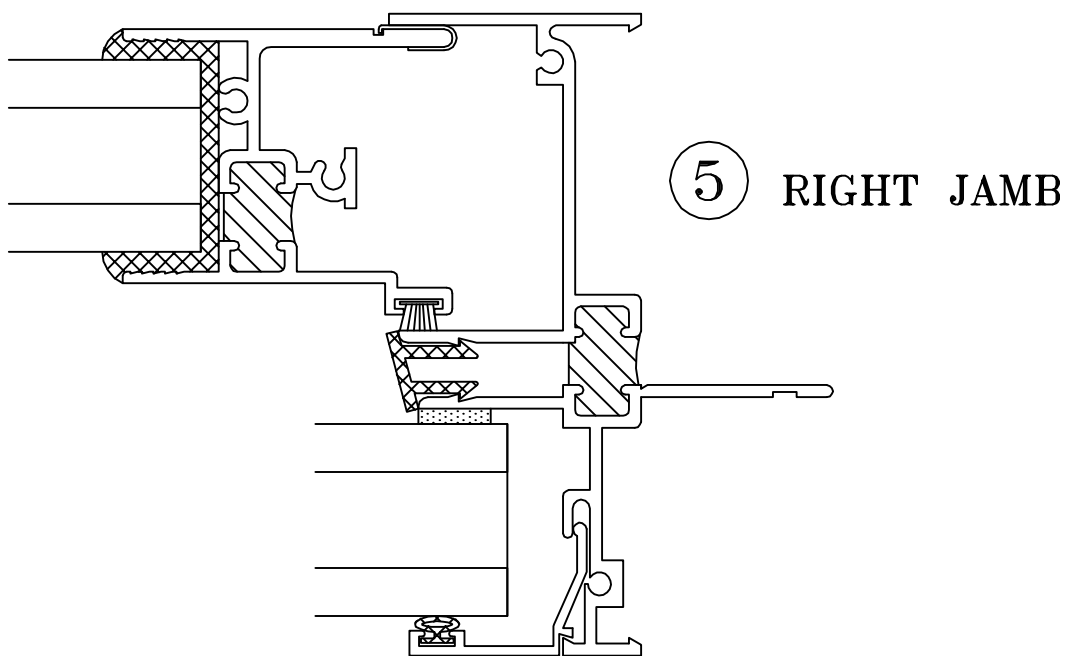
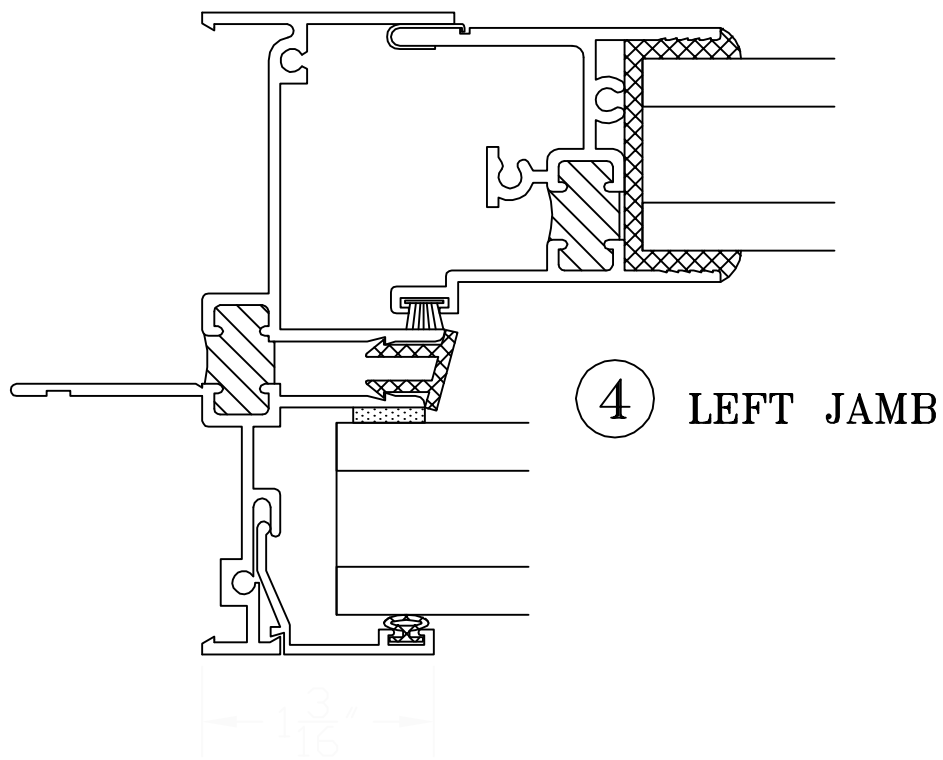

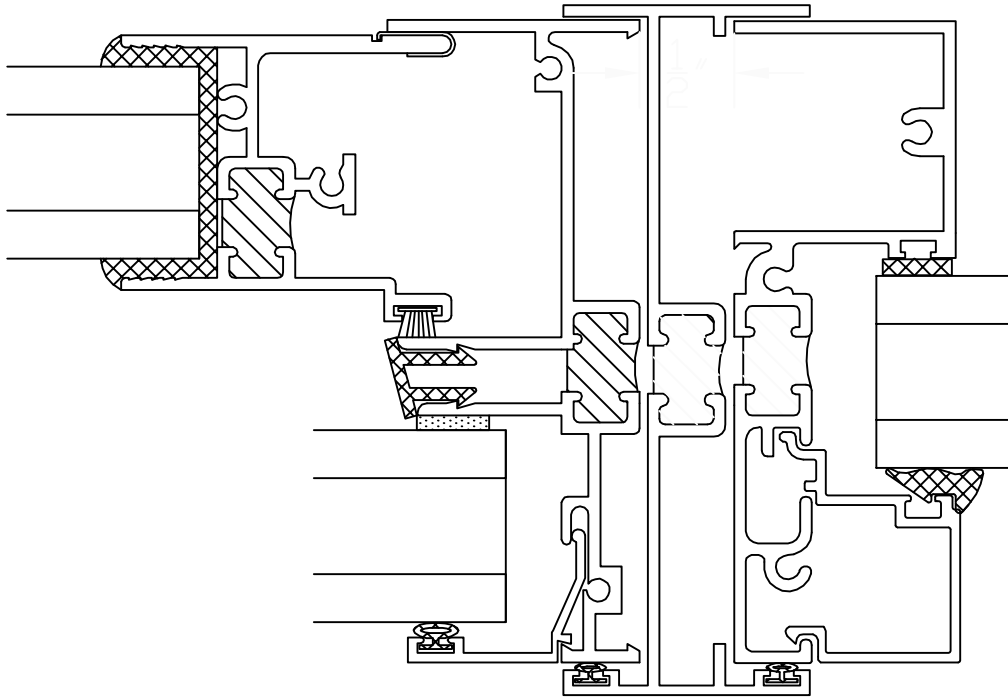

⑥ STACK BAR W/FIXED @ RIGHT

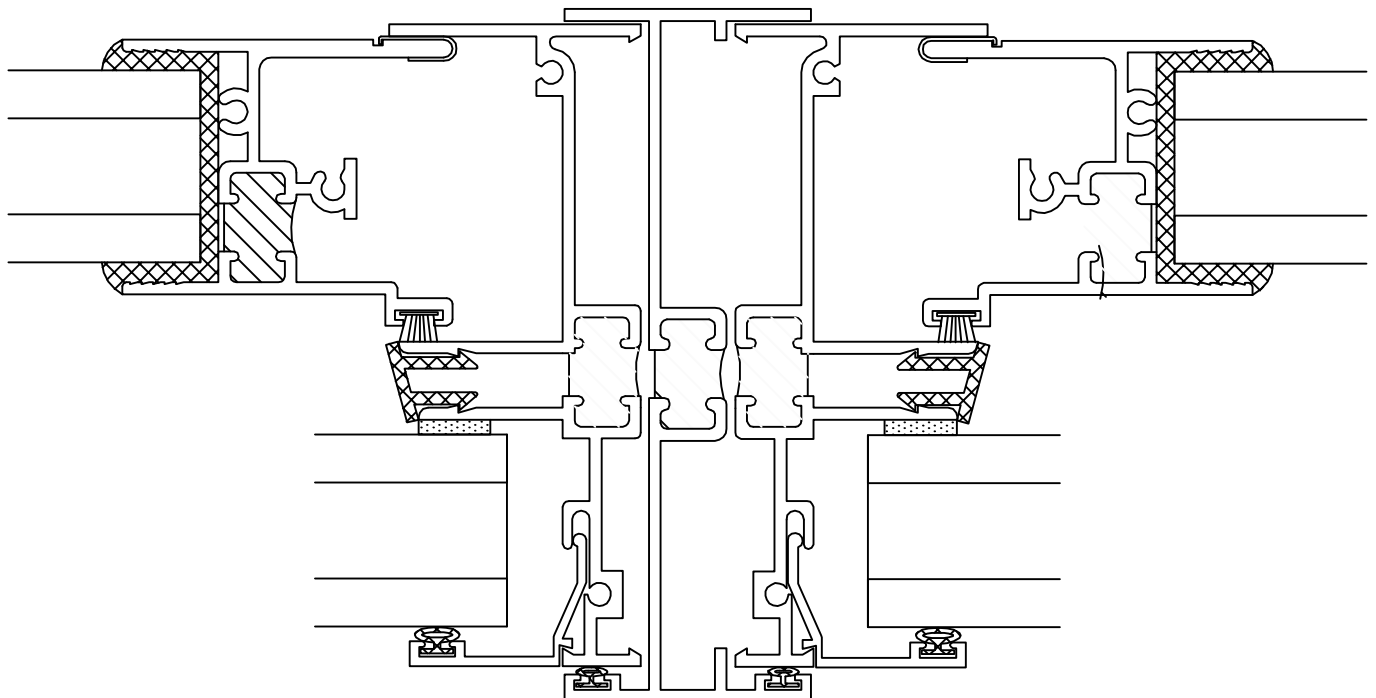

⑦ STACK BAR